

Please keep your operating instruction in a safe place!
Translation of the original operating instructions!

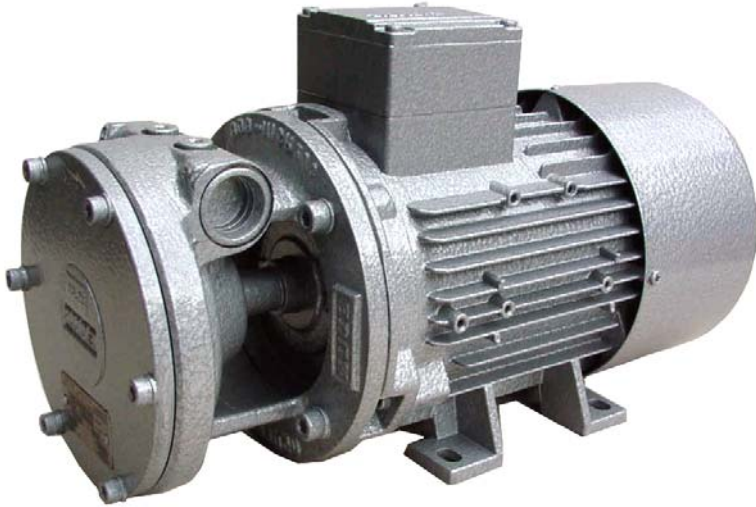

Operating Instruction for Peripheral Pumps

PBU / PBM

Serial No.

Type



Persons with a Heart Pacemaker
must not install service or operate the
pump ! (only PBM)



EDUR-Pumpenfabrik
Eduard Redlien GmbH & Co. KG

Postfach 1949 · D-24018 Kiel
Tel. (+431) 689868 · Fax (+431) 6898800
E-mail: info@edur.de · <http://www.edur.com>

Contents

1	General information	3	6	Service/Maintenance	8
1.1	Design	3	6.1	Supervision of Operation	8
1.2	Intended Use	3	6.1.1	Shaft Bearing	9
1.3	Place of Operation	3	6.1.2	Mechanical Seal	9
2	Safety	4	6.2	Maintenance	9
2.1	Marking of Instructions in the Operating Instructions	4	6.2.1	Preparations	9
2.2	Personnel Qualification and Training	4	6.2.2	Dismounting	9
2.3	Dangers in the Event of Non-compliance with Safety Instructions	4	6.2.2.1	Pump	10
2.4	Responsible Working Practices	4	6.2.2.2	Dismounting of Mechanical Seal	10
2.5	Safety Instructions for the User/Operator	5	6.2.2.3	Motor	10
2.6	Safety Instructions for Maintenance, Inspection and Mounting Work	5	6.2.3	Mounting	10
2.7	Unauthorized Conversion and Production of Replacement Parts	5	6.2.3.1	General Remarks	10
2.8	Impermissible Modes of Operation	5	6.2.3.2	Mounting of Mechanical Seal	10
3	Transport and Intermediate Storage	5	7	Disturbances	12
3.1	Intermediate Storage	5	8	Pump View and List of Spare Parts	13
3.2	Internal Preservation	6	8.1	PBU	13
3.3	Preservation Control	6	8.2	PBM	14
3.4	Removal of Preservation	6			
4	Mounting	6			
4.1	Installation	6			
4.2	Connected Loads	6			
4.3	Direction	6			
4.4	Protective equipment	7			
4.5	Piping	7			
4.5.1	General Remarks	7			
4.5.2	Suction Pipeline	7			
4.5.3	Pressure Pipeline	7			
4.5.4	Additional Connections	7			
5	Starting Operation/Stopping Operation	8			
5.1	Preparations for Initial	8			
5.2	Initial Starting	8			
5.3	Restarting	8			
5.4	Stopping Operation	8			

Translation

When shipping to EEA Countries, the operating instructions are to be translated into the respective language of the country where the device is to be used. In the event that discrepancies arise in the translated text, the original operating instructions (German) are to be consulted or the manufacturer is to be contacted in order to clarify the discrepancy.

Copyright

The forwarding and reproduction of this document, the use and disclosure of the contents of this document is forbidden unless explicitly permitted. Failure to comply with this will result in liability for damages.

All rights reserved.

1 General information

The most important operating data can be found on the identification plate. **It must be ensured that the pump type and all technical data correspond to the system / machine project data.** It must be observed that the electric motor is provided with its own identification plate complete with additional technical data. The motor data must also correspond with the system / machine project data.

The separately enclosed operating instructions are also to be observed when dealing with pumps in accordance with EC Directive 94/9/EC (ATEX). These instructions contain additional instructions and requirements with regards to the correct and proper use of pumps in potentially explosive areas.

The pumps may not be commissioned until the following points have been observed / ensured:

- Inappropriate physical and mental strain placed upon the operation staff must be reduced to an absolute minimum level by taking ergonomic principles into account.
- A safe working environment must be guaranteed. Controls are to be designed and constructed in such a manner that no hazardous situations can occur. Furthermore, such situations may not occur even in the event of faults / breakdown of the control. In particular, the pump may not be unintentionally started. It must also be the case that the supply / discharge lines to and from the pump can also be closed.
- It must be guaranteed that the pump can be safely stopped. Irrespective of the type of operation, the EMERGENCY STOP function must be available and ready for operation at all times. In doing so, it must be taken into consideration that equipment connected to the pump can also be stopped in the event that a hazard can occur if such equipment continues to be operated.
- The supply / discharge lines must be able to withstand the possible internal and external pressure loads
- By implementing suitable precautions, it must be ensured that no injuries can occur by touching the pumps, e.g. with regards to extreme temperatures.

- When conveying materials that pose a hazard to health / environment, it must be ensured that these materials can also be collected and taken away safely. Any risk with regards to inhalation, ingestion as well as contact with the eyes, skin and mucus membranes must be prevented.

1.1 Design

Pump in unit-construction with electric drive unit, with a pump/motor shaft of different materials, sizes and with different shaft sealings.

1.2 Intended Use

Temperature:

PBU: 80°C up to (140°C)
PBM: up to 200°C

Operating Pressure:

PBU / PBM: max. 16 bar

Viscosity:

Ambient Temperature: -20°C up to 40°C

Power adjustment

The power of the motors is to be reduced in accordance with the guidelines provided by the motor supplier in the event that the motors are positioned in ambient temperatures of above 40°C or in a location that is more than 1000m above sea-level.



The conveying of liquids that may chemically corrode the pump material or that contain abrasive components will destroy the pumps. The conveyed material must be suitable for use with the pump material.

The power consumption of the pump proportionally changes based upon the density of the conveyed material. The densities must correspond to the order data in order to avoid excess strain being placed upon the pump and motor.

1.3 Place of Operation

The pump unit must be freely accessible for the purpose of supervision, servicing, maintenance, mounting and dismounting. Avoid using it in corrosive and very dusty surroundings.

The limiting values of the electric drive unit with regard to the insulation material class and the types of protection must be observed.

The most important operational data are mentioned on the type label. The sound pressure produced by the peripheral pump does not exceed the value 70 dB(A).

Increased noise emissions may be caused by cavitation, faulty / worn bearings or vibrations. Installation, maintenance and service instructions are to be observed.

2 Safety

These operating instructions contain basic safety instructions for installation, operation and maintenance. It is therefore essential that they are read by fitters and all specialist staff and customer personnel prior to installation and start-up. They must always be kept at hand at the place of installation.

The special safety instructions contained in the other chapters must be observed in addition to the general safety instructions in this chapter.

2.1 Marking of Instructions in the Operating Instructions

The safety instructions contained in these operating instructions which represent a danger to personnel if not complied with are specially marked by the general danger symbol:



Warning symbol
as per DIN 4844-W9

Warning of danger from electric voltage is given as follows:



Warning symbol
as per DIN 4844-W8

Instructions which are essential to avoid endangering the machine and its functioning are marked by the word

CAUTION

Instructions affixed directly to the machine such as

- Directional markers
- Signs for fluid connections

must always be observed and maintained in fully legible condition at all times.

2.2 Personnel Qualification and Training

The operating, maintenance, inspection and mounting personnel must be appropriately qualified for the duties assigned to them. The scope of their responsibilities, competency and supervisory duties must be closely controlled by the customer. If the personnel do not have the required knowledge, they must be trained and instructed. If required, this may be provided by the manufacturer/supplier on behalf of the customer. The customer must additionally ensure that personnel fully understand the content of the operating instructions.

2.3 Dangers in the Event of Non-compliance with Safety Instructions

Failure to comply with the safety instructions may result in danger to persons, and place the environment and the machine at risk. Non-compliance with the safety instructions may lead to the loss of any claims for damages.

Non-compliance may relate to the following dangers:

- Failure of important functions of the plant
- Failure of specified methods for maintenance and servicing
- Danger to persons resulting from electrical, mechanical and chemical effects
- Danger to the environment resulting from leakage of hazardous substances



Injuries to hands can occur during maintenance and repair works. Ensure that all safety instructions are observed.

Danger areas on the pump

During maintenance and cleaning work, an area measuring approximately 1 m around the pump will serve as a danger area. This area may also be increased in size in the event of faults. The operating area is only located at the operation elements.

2.4 Responsible Working Practices

The safety instructions contained in these operating instructions, current national accident prevention regulations, as well as internal working, operating and safety rules of the customer, must be observed.

2.5 Safety Instructions for the User/Operator

- Hot or cold parts representing a danger must be protected against accidental contact on site.
- Protection against accidental contact for moving parts (such as the coupling) must not be removed while the machine is in operation.
- Leakage (e.g. from the shaft seal) of hazardous substances being handled, such as explosive, toxic or hot materials, must be discharged such that no danger to persons or the environment is created. Legal regulations must be observed.
- Dangers from electrical energy must be eliminated. For details in this regard, refer to VDE and local power company regulations.

2.6 Safety Instructions for Maintenance, Inspection and Mounting Work

The operator company shall ensure that all maintenance, inspection and mounting work is performed by authorized and qualified specialist personnel who have thoroughly studied the operating instructions.

Work on the machine is only to be carried out when the machine is at a standstill. The means of shutdown of the machine described in the operating instructions must always be followed.

Pumps or aggregates handling fluids which are detrimental to health must be decontaminated. All safety and protective devices must immediately be refitted and made operational on completion of the work.

Replacement parts that have not been supplied by the manufacturer are not tested and not approved for use. The installation and usage of such replacement parts can have a negative impact upon the pump characteristics.

The manufacturer is not liable for any damages caused by the usage of non-original parts.

Pumps or aggregates handling fluids which are detrimental to health must be decontaminated. All safety and protective devices must immediately be refitted and made operational on completion of the work.

The instructions under Section 5.1, „Preparation for Initial Operation“, must be observed before restarting.

2.7 Unauthorized Conversion and Production of Replacement Parts

Conversion or modification of the machines is only permissible after consultation with the manufacturer. Original replacement parts and accessories approved by the manufacturer serve safety purposes. If other parts are used the manufacturer cannot be held liable for the consequences.

2.8 Impermissible Modes of Operation

The operating safety of the machine supplied is only ensured when it is used in accordance with Section 1 of the operating instructions. The limit values given on the data sheet must under no circumstances be exceeded. The pump may only be operated in the authorised curve range.

3 Transport and Intermediate Storage

The pump unit must be transported in a level or horizontal manner.



A pump that is insufficiently secured can lead to persons being seriously injured.

Hoisting equipment and slinging belts are to be sufficiently measured for the entire weight of the pump.

If necessary, ensure that the pump is secured during transport with the use of appropriate slinging equipment. The pump is only to be positioned on a surface that is sufficiently solid and is level in all directions.

3.1 Intermediate Storage

On delivery, all pumps are preserved. Thus, they can be stored for 6-12 months. If the storage time is longer or the pumps are not in operation, they must receive additional preservation on the inside. The preserving means (please consult us) depends on the used materials and conditions of operation.

The storage room must be roofed and well ventilated. Avoid temperatures below zero and high humidity.

3.2 Internal Preservation

Close the suction branch securely. Fill the pump with the preservative means and slowly turn the rotor manually. Close the pressure branch securely.



A rotating impeller can cut or crush hands and arms. Do not reach into the pressure or suction sockets of the pump housing.

3.3 Preservation Control

Check the filling level of the pump and turn the rotor by hand at regular intervals of 3 months. Refill preservative means, if necessary.

3.4 Removal of Preservation

Prior to operation, the pump must be rinsed thoroughly. In the case of additional preservation, the preservative means on the inside must at first be removed.

4 Mounting

4.1 Installation

Irrespective of the fitting position, pumps in unit-construction can be installed on a pedestal by means of a base.

The installation position "motor faced down" is only permitted with the manufacturer's approval. The pedestal must be even with sufficient load capacity and must have fasteners. In the case of selfpriming pumps, the inlet bend must not be removed or turned around.



Physical injury can occur during the pump installation phase.

Safety regulations and the generally recognised engineering regulations are to be observed.

The operator is to ensure a direct and barrier-free access to the pump and must also guarantee good visibility conditions. The operator is to protect the pump against environmental impacts (wind, rain, frost, sand, etc.).

4.2 Connected Loads



Work must only be executed when electricity is switched off. Make sure that the system cannot be powered on accidentally.

CAUTION

An overload protection system (e.g. motor protection switch, etc.) must be in place in order to protect the pump and the motor.

The separately enclosed motor safety guidelines and instructions are to be observed.

When using motors that are equipped with frequency converters (FC), the safety guidelines and instructions contained in the separately enclosed FC operating instructions are to be observed. An appropriate risk analysis is to be carried out by the system operator due to the fact faults and malfunctions of the frequency converter cannot be completely prevented as a result of electro-magnetic radiation.

Prior to connecting the pump to the power system, fill it with pumped liquid. The pump must by no means be operated without liquid!

The pump must be connected according to international national requirements as well as according to the requirements of the local mains system. Voltage and frequency must correspond to the winding of the electric drive. For details of the respective wiring, see the type label.

The motor must not be operated without motor protection facility.

For motors with explosion protection, the range of temperature of the motor indicated on the type label must correspond to the range of the fuel gas.



Overheating damages the three-phase alternating current motor.

Ensure that a sufficient supply of cool air is in place during operation.



Electrical power can lead to death.

Ensure that a potential equalisation connection is in place between the pump housing and the building earthing.



Incorrect electrical switching modes will lead to the breakdown of the three-phase alternating current motor. Observe the switching mode.

4.3 Direction

Switch on the motor briefly in order to check the direction of rotation. The motor must not reach its operational speed. The direction of rotation must correspond to the arrow indicating the direction of rotation on top of the pump. If the direction of rotation is not correct, perform the relevant modifications at the phase-sequence.

CAUTION

The switching on / operation of opened pumps (outside of the pipe line network) is forbidden.



A rotating impeller can cut or crush hands and arms. Do not reach into the pressure or suction sockets of the pump housing. Secure the pump appropriately when carrying out a rotational direction check.



The dry operation of the pump destroys / damages the mechanical seal and leads to leakage and the discharge of the conveyed material. Ensure that the pump is switched off again immediately after the warm-up phase.



The incorrect rotational direction of the pump destroys / damages the mechanical seal and leads to leakage and the discharge of the conveyed material.

4.4 Protective equipment

CAUTION

In the event that hot or cold pump parts lead to hazards, appropriate protective measures (contact protection) are to be installed on-site. Operation without affixed protective equipment is forbidden.

4.5 Piping

4.5.1 General Remarks

Pressure lines are to be laid in accordance with the respectively valid guidelines as well as the relevant accident prevention regulations. Pipe lines and pumps are to be secured against tripping. If required, a safety area is to be provided against tripping.

The flange covers located on the suction and pressure sockets on the pump are to be removed before installing into the pipe line. The containers, pipe lines and connections must be thoroughly cleaned and rinsed before commissioning. It is often the case that welding beads, scale and further contaminants only disengage after some time. These contaminants are to be kept away from the pump by implementing appropriate measures, e.g. using a filter in the suction line.

CAUTION

Observe the conveying and connection direction (suction / pressure flange) of the pump. An incorrect conveying direction of the pump can lead to system faults.

The nominal widths of the pipes must be at least as wide as those of the pump connection joints. For adapters, use extension angles of 8°, if possible.

The pipes must be gathered and secured right in front of the pump so that their weight does not affect the pump. The negative effects of variations in temperature and occurring oscillation may be reduced by installing a suitable bellow expansion joint.

Measuring equipment for supervision of the pump operation is required.

Prior to operation, all parts in contact with liquids must be thoroughly cleaned.

CAUTION

Under no circumstances may the pump be used as a fixed point for the pipe line. No loads or torques arising from the pipe line system, e.g. as a result of twisting, heat expansion, etc. may have an impact on the pump.



Hot and discharged conveyed materials pose a risk to life.

Do not exceed the permitted pipe line forces.

4.5.2 Suction Pipeline

The suction pipeline must be as short as possible. Variations in diameter and additional piping must be kept to a minimum. The suction pipeline towards the pump must be rising, the inlet must be descending to prevent an air pocket from being formed. For non-selfpriming pumps, installation of a foot valve into the suction pipeline is compulsory in order to avoid that, in case of a standstill, the pump and the suction pipeline run out of liquid during suction operation.

Contamination of the pumped liquid is to be avoided by using a suction hose or a filter. By no means must air penetrate through the liquid level via the suction hose or dirt be whirled up from the liquid pool. Clean the suction hose and filter regularly.

To close the suction pipeline in the case of mounting or maintenance work, a stop valve must be provided near the pump. The stop valve must not be used for adjustment and must be completely open during operation.

4.5.3 Pressure Pipeline

For adjustment, repair and mounting of the pump, a stop valve is to be provided near the pressure joint.

4.5.4 Additional Connections

Connections for ventilation and release of the leakage liquid are also described in the drawings.

5 Starting Operation/Stopping Operation

5.1 Preparations for Initial

Prior to the start, the pump and the suction pipeline must be drained of air and be completely filled with the pumped liquid. The stop valve in the suction or inlet pipeline must be completely open, if there is one.

CAUTION A pump / pipe line that is not de-aerated leads to the destruction / damage of the mechanical seal. Conveyed material may be discharged.

Before commissioning, it must be ensured that the pump and pipe lines have been connected / assembled in accordance with the guidelines and in a fixed manner. The pump may only be operated provided that protective equipment (coupling protection / fan guard) is in place. The pump must be operated with contact protection when dealing with hot conveyed material.

CAUTION Do not block the motor fan with foreign articles. Blockage will lead to the ejection of foreign articles and overheating / breakdown of the motor.

5.2 Initial Starting

The pump must not be started until the outlet stop valve is opened so as to avoid overstressing the motor. Immediately after reaching the operational speed, slowly close the stop valve of the pressure pipeline and adjust the operating point.



The pump must never be operated for a longer period if the outlet stop valve is closed. The pump unit will be damaged if the pumped liquid exceeds the permitted temperature.

5.3 Restarting

Do not restart the pump until the pump shaft stands still.

Backflow of liquid must not result in a change of direction of rotation of the pump. If this is the case, mechanical seals dependent on direction of rotation may be damaged.

CAUTION Before re-starting the pump, it must be ensured that the pump has not incurred any damage during the downtime and that all safety and protective equipment is affixed.

5.4 Stopping Operation

Switch off the motor and observe that it slows down smoothly. Close stop valve of the suction or inlet pipeline. If there is a backflow stop and sufficient counter pressure in the pipeline, the stop valve can remain open.

If the pumped liquid reaches temperatures below zero and/or if longer periods of standstill occur, the pump must be drained completely and be preserved (see section 2.1).

6 Service/Maintenance

6.1 Supervision of Operation

CAUTION The pump is to be secured against being unintentionally switched on during maintenance and cleaning work. Work may only be carried out provided that the system / pump is in a pressure-free condition.

Maintenance and cleaning work may only be carried out by expert staff members. The expert staff members must be provided with personal protective equipment.

Ensure that the pump is cleaned and maintained at regular intervals in order to be able to ensure a trouble-free operation.

CAUTION Conveyed material that poses a hazard to health can place a person's health at risk. The operator is to equip the system with collection equipment or other appropriate protective measures. Personal protective equipment such as gloves and protective goggles must always be worn.

Ensure that the pump runs in a quiet and vibration-free manner. Inspect the pump for loose connections at regular intervals (an interval of 4 months is recommended). Regularly remove deposits of dust as well as contaminations.



Physical injury can occur when carrying out maintenance and cleaning work on the pump.

Safety regulations and the generally recognised engineering regulations are to be observed.

The pump must by no means be operated without liquid.

There is only a minimal or invisible loss of leakage (steam) if the mechanical seals function correctly. Do not operate the pump for a longer period with a closed stop valve.

The maximum permitted environmental temperature is 40°C. The storing temperature measured at the motor or pump casing may exceed the environmental temperature by 50°C. It must not exceed 90°C.

Only operate the pump at a higher temperature with the manufacturer's approval.
Installed pumps must be powered on and off briefly once a week in order to guarantee that they are ready for operation.



Insufficient rotary motion of the motor shaft will lead to the impeller becoming stuck and the mechanical seal breaking down. This can lead to the discharge of the conveyed material.

6.1.1 Shaft Bearing

Under normal operation conditions, replace the motor bearings after 20.000 hours of operation or at the latest after 2,5 years. In the case of bad operation conditions, as e.g. a high environmental temperature or a corrosive and dusty environment, the motor bearings must be checked at an earlier date and, if necessary, be replaced. Faulty / worn bearings lead to subsequent damage and can result in increased noise emission.

6.1.2 Mechanical Seal

The mechanical seals are maintenance-free. If leakages occur after a longer period of operation, replace the complete seal.

CAUTION When dealing with conveyed materials that pose a hazard to health and to the environment, the operator is to equip the system with collection equipment or other appropriate protective measures. Personal protective equipment such as gloves and protective goggles must always be worn.

6.2 Maintenance

6.2.1 Preparations



In order to make sure that the pump cannot be started, separate the power cable from the motor. Secure the unit against accidental switch-on.

The stop valves located in the pressure and suction line are to be closed and secured against unauthorised opening.

The pump casing must have reached the environmental temperature and be drained of liquid and pressure.



Leaking conveyed material can injure hands and arms. Ensure that the pump housing is in a pressure-free condition. Only then may the pump be emptied.



When dealing with pumps that have been used to convey materials that pose a hazard to health / to the environment, ensure that no danger to persons and the environment can occur when emptying the pump. Wear appropriate protective clothing and, if required, protective mask. The rinsing liquid used and the remaining liquid located in the pump must be professionally collected and disposed of without posing any hazards to persons or to the environment.



There are strong permanent magnets inside the pump. Magnetic fields are detectable in the immediate vicinity of magnet rotors when they are disassembled. Persons with **heart pacemakers** fitted should not mount, service or operate the pump.

6.2.2 Dismounting

By no means use force while dismounting the pump.



Pumps that are used to convey material that is hazardous to health and to the environment must be decontaminated. When releasing the material, ensure that no danger to persons and the environment can occur when emptying the pump. Legal requirements are to be observed and adhered to.



The pump must always be secured against tipping over. There is a risk of tipping over when loosening the pump from the outside of the pipe line network. Persons can be seriously injured if the pump tips over. During the transport phase, ensure that the pump is secured using appropriate slinging equipment. The pump is only to be positioned on a surface that is sufficiently solid and is level in all directions.



CAUTION The pump may only be dismantled when in a pressure-free, empty, de-contaminated (if required) and secured condition. Protective clothing and protective mask must be worn if required.

Separate the pumps from the piping and any additional connections. Loosen the fasteners from the base.

Impellers, which cannot easily be removed from the shaft, can be pushed back from the shaft by means of two hexagon screws.

6.2.2.1 Pump

Continue dismantling the pump as described in the drawings on page 7.

Mark the position and sequence of the pump parts for later mounting.



The existent magnetic forces may cause injury if inadequate care is taken and/or loose parts are lying around.



When removing the magnetic drive components, strong magnetic forces are at work. The components may be pulled back to their original position by the force of the magnets.

To avoid injury to persons, screw in forcing screws of appropriate length so that the distance between the components is large enough to prevent hands or fingers from being trapped or crushed.

6.2.2.2 Dismounting of Mechanical Seal

To replace the mechanical seal, the pump must first be dismantled.

After removal of the cover (160), the impeller (230) and the shaft circlip (932), the complete mechanical seal can be removed with its casing (100).

6.2.2.3 Motor

To dismantle the motor, the pump must normally be completely dismantled.

6.2.3 Mounting

6.2.3.1 General Remarks

Prior to mounting, all parts must be cleaned thoroughly. Remove remaining parts of the seals. Slight scratches and grooves on the shaft near the shaft seal and on other sealing surfaces of the casings are to be polished with linen. If this is not possible, replace the parts. Check O-rings for damage and replace them, if necessary. Mounting is effected in the reverse order of dismantling.

When replacing the cover (160) onto the casing (100), make sure that the arrow indicating the direction of rotation is exactly between the connection joints of the pump.



The existent magnetic forces may cause injury if inadequate care is taken and/or loose parts are lying around.



When mounting the magnetic drive components, strong magnetic forces act between the components. The components may be quickly pulled to their final position by the force of the magnets. The inserted long forcing screws prevent hands or fingers from being trapped or crushed between the components.

6.2.3.2 Mounting of Mechanical Seal



When mounting the mechanical seals, you must proceed very carefully and with precision.

Do not touch the surfaces of the seal. Do not damage the sealing parts. To facilitate the mounting, moisten elastomer with low-surface tension water.



Mechanical seals and sealing parts with elastomer made of EP caoutchouc must by no means come in contact with oil or grease.

The shape of spare mechanical seals may differ from those of the installed mechanical seal. However, the dimensions of the spare mechanical seal are the same and for that reason it can be replaced.

For details of the individual types of mechanical seals observe the following procedures.



Observe the enclosed, separate mounting instructions for those types of mechanical seals which are not listed.

1. Stressed mechanical seal independent of direction of rotation with elastomer bellows (fig. 6.2.3.4a)

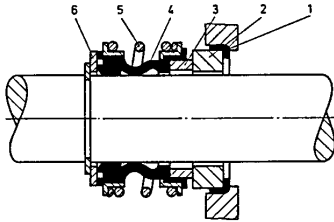

Fig. 6.2.3.3a

Carefully press angle collar (1) together with counter ring (2) into the counter ring fit. Twist the rotating unit (3,4,5) onto the shaft as far as the counter ring. Put on supporting ring and mount circlip (932) and/or, push shaft sleeve for mechanical seal (516) onto the shaft.

2. Loaded, rotational direction-dependent mechanical seal with conical spring (Fig. 6.2.3.3b)

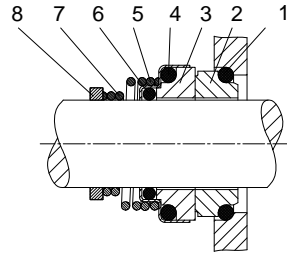

Fig. 6.2.3.2b

Place the O-ring (1) in the counter ring seat and carefully insert the counter ring (2). Press the rotating unit (3, 4, 5, 6, 7, 8) on to the shaft whilst rotating.

Attach the impeller (230)* (only when dealing with CB..., CBF..., ECD..., SU... pumps) or

Assemble the safety ring (932)* / push the slide ring sleeve (516)* onto the shaft.

7 Disturbances

Pump is blocked	Coupling fault	Heads too low	Rates of flow too low	Bearing temperature too high	Pump operates badly	Leakages at the casings	Overtressing of the drive	Shaft seal leaks badly	Motor protection activated	Pump is becoming too hot	CAUTION	To eliminate disturbance, the pump must have reached the environmental temperature and must be drained of air and pressure.
											Cause	Elimination
		•	•								Pump and/or suction pipeline is not completely drained of air/filled	Drain of air and fill
		•	•	•						•	Suction level too high, NPSH value of the unit too high	Completely open stop slide in the suction pipeline, check suction bag/footing valve, if necessary, increase liquid level, if necessary
		•	•							•	Air inclusion in the pumped liquid too high	Seal suction pipeline once again, check suction bag, increase liquid level, if necessary
		•	•	•						•	Formation of air bag in suction pipeline	Change suction pipeline/attach drain valve
		•	•								Direction of rotation incorrect	Check and change phasequence, if necessary
		•	•							•	Rates of flow too low	Readjust operating point
		•	•								Wear of inner parts	Replace inner parts
				•			•			•	Pump operates out of tolerance	Readjust operating point
											Shaft seal damaged	Replace shaft seal bzw.
		•	•								Speed too low	Increase speed ¹⁾
											Speed too high	Reduce speed ¹⁾
							•				Seals	Replace seals
				•							Pump/motor not adjusted	Replace defective parts, adjust pump/motor
				•	•						Problems via piping	Check pipe connections/pump fasteners/bearing distance of pipe clips, installation with oscillation absorbers
•											Defective bearing	Replace bearing
		•	•					•		•	Density/viscosity of pumped liquid higher than indicated in the order	¹⁾
											Motor protection unit set incorrectly or defective	Check motor protection unit, replace it, if necessary
•											Impeller blocked	Clean interior parts from particles and impurities

¹⁾ Please consult us

8 Pump View and List of Spare Parts

8.1 PBU

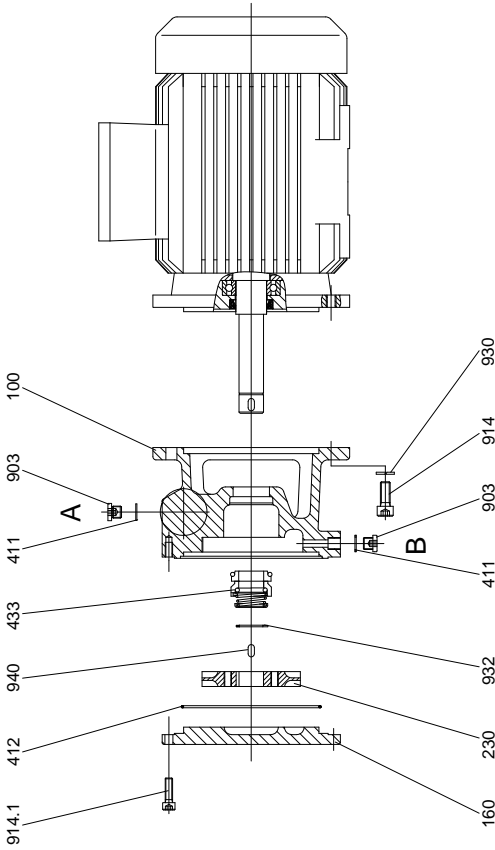

part no.	designation	part no.	designation	part no.	designation
914.1	casing	412	o-ring	914/1	hexagon socket head cap screw
160	cover	433	mechanical seal	930	tooth lock washer
230	impeller	507	deflector	932	circlip
411	joint ring	903	screwed plug	940	key

A: Screwed plug G¹/₈ for vent and manometer connection

B: Screwed plug G¹/₈ for drain

When ordering spare parts, please indicate serial no., type no. and parts no. by all means.

EG Declaration of Conformity
In accordance with EC Machinery Directive 2006/42 EC, Appendix II, 1 A

We,

EDUR Pumpenfabrik Eduard Redlien GmbH & Co. KG
Hamburger Chaussee 148-152
D-24113 Kiel

hereby declare that the compact design rotary pump – see cover sheet for information regarding pump model, conforms to all of the relevant regulations of EC Machinery Directive 2006/42/EC. The protection objectives of the low voltage directive were observed in accordance with Appendix I, No. 1.5.1 of the machinery directive.

The following harmonised standards applied:

DIN EN 12100-1
DIN EN 12100-2

DIN EN 809
DIN EN 14121

Person responsible for the documentation: A. Weiss

